



INTERNATIONAL CONSTRUCTION CONSORTIUM (PVT) LTD

PRE-CAST PRODUCTION

PRE-CAST MAN HOLE & VALVE CHAMBER WITH COVER SLABS



DATA SHEET

PRECAST
BASE UNITS

PRECAST
COVER
SLABS

TOP
SEGMENTS

QUALITY
PRECAST
MAN HOLES &
VALVE CHAMBERS

INTERMEDIATE
SEGMENTS



ICC PRECAST
FAST - QUALITY - INNOVATIVE



PRE-CAST PRODUCTION

PRE-CAST MAN HOLE & VALVE CHAMBER WITH COVER SLABS

DATA SHEETS

01. INTRODUCTION

International Construction Consortium (Pvt)Ltd is the leading manufacturer of precast man holes,hand hole, catch pit ,valve chambers and associated precast products in Sri Lanka. They are available in wide range of sizes as per project specifications.

The manufacturing of precast man holes,hand hole, catch pit and valve chambers are done with high quality controlling and quality assurance systems with engineer supervisions.

This publication provides the information necessary to specify this products for all of these applications.



02. GENERAL SPECIFICATIONS

STANDARD SPECIFICATION

Water Board Standard
Project Standard

PRODUCTION SPECIFICATION

Dimensions: As per project specifications
Concrete Strength(N/mm²): Grade 35A, 40
Connecting Type : Specified key

RAW MATERIAL SPECIFICATION

Cement: SLS 107 : 2015
: BS EN 197 - 1:2011
Fine Aggregate: BS 882 - 1992
Coarse Aggregate: BS 882 - 1992
Reinforcement Steel : SLS 375 : 2009
Water : BS 3148 - 1980

03. PRODUCT RANGE & DETAILS

- Bottom (Base) segment
- Intermediate segment
- Top segment
- Cover slabs



PRE-CAST PRODUCTION

PRE-CAST MAN HOLE & VALVE CHAMBER WITH COVER SLABS DATA SHEETS

04. PRODUCT DETAILS

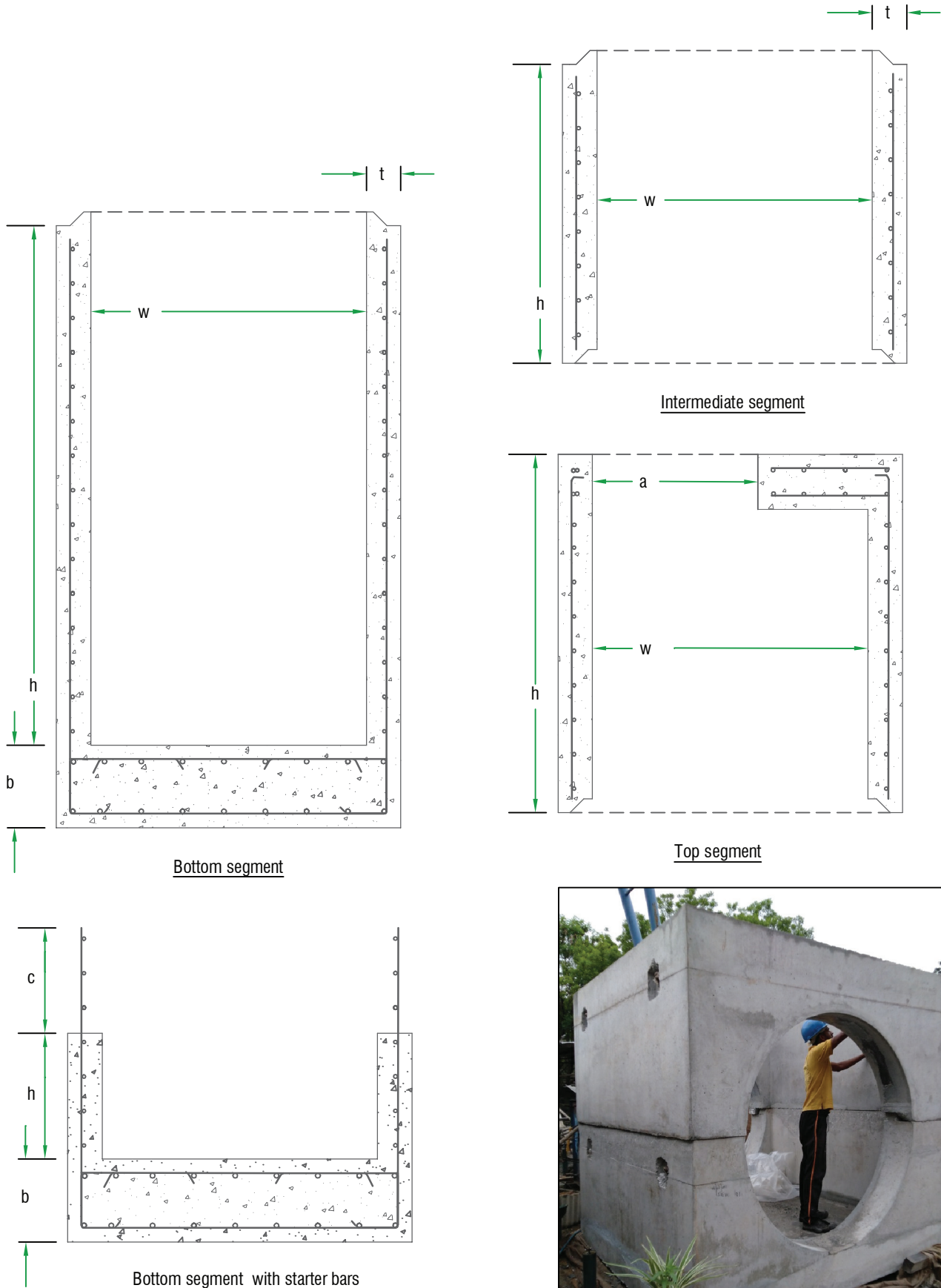

Figure 05



PRE-CAST PRODUCTION

PRE-CAST MAN HOLE & VALVE CHAMBER WITH COVER SLABS DATA SHEETS

*Available mould sizes for man hole circular & Square types.

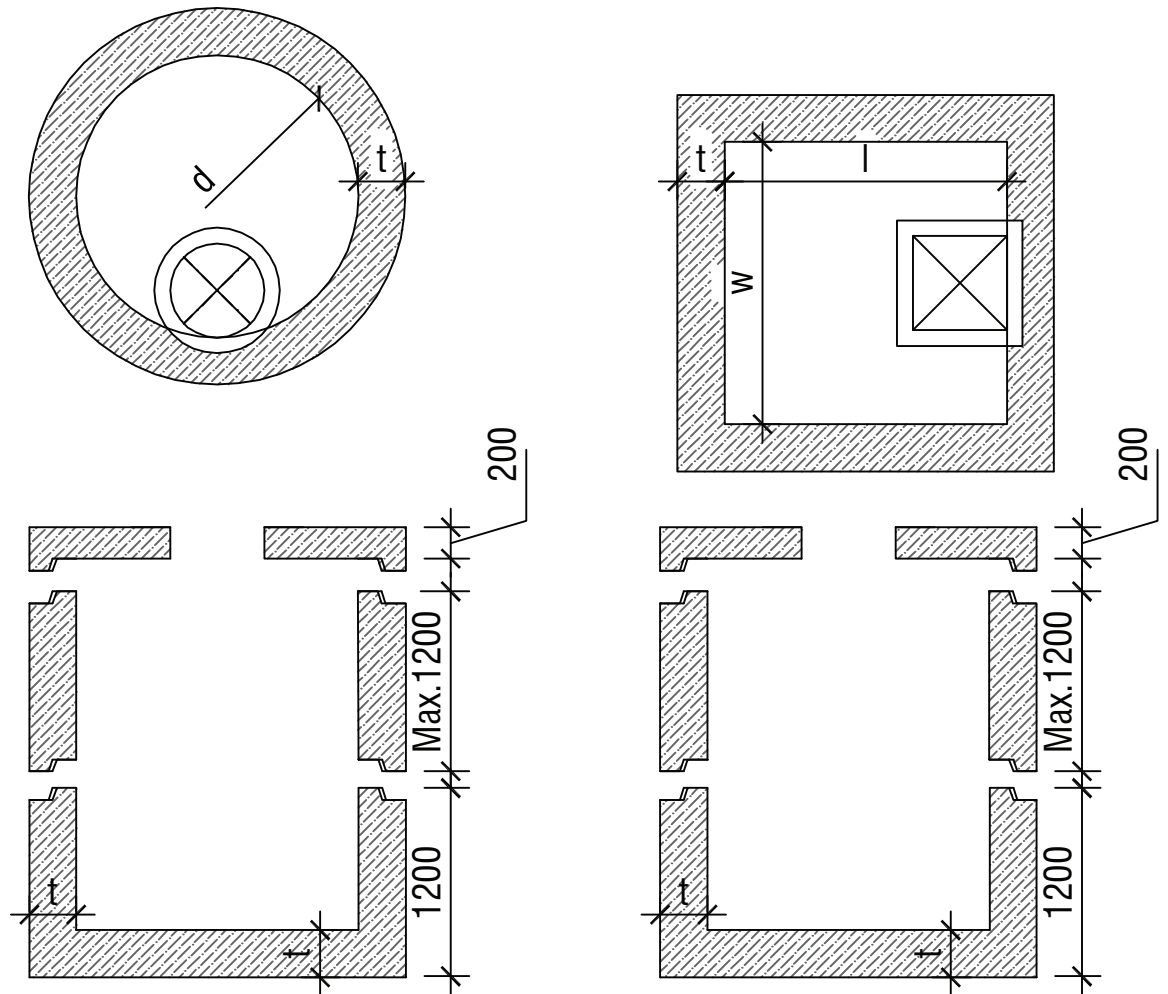

Table 01

Square Type	l- (mm)	w- (mm)	t- (mm)	Inter Segment Height - (mm)	Appo. Weight (kg)
A	1000	1000	300	1200	9400
B	1500	1500	300	1200	10300
C	1800	1800	300	1200	11100
					12000

Table 02

Circular Type	d- (mm)	t- (mm)	Inter Segment Height - (mm)	Appo. Weight (kg)
A	1200	300	1200	9400
B	1200	300	1200	10300
C	1320	300	1200	11100
D	1400	300	1200	12000
E	1500	300	1200	12000
F	1600	300	1200	12000
G	1800	300	1200	12000

Segments casting done by the inclusive of any provisions (Opening requirements, Rungs, Lifting hooks, Etc.) for site/customer requirements.

Segment weight is vary by the opening requirements.



PRE-CAST PRODUCTION

PRE-CAST MAN HOLE & VALVE CHAMBER WITH COVER SLABS DATA SHEETS

* Available mould sizes for catch pit and hand hole Square types.

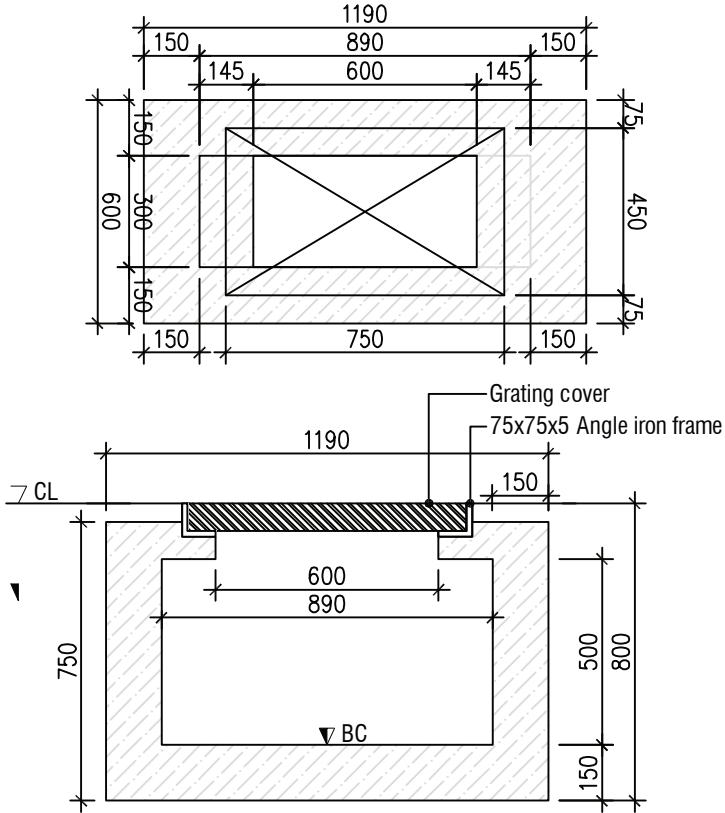

Figure 06



Figure 07



Figure 08



Figure 09



Figure 10



PRE-CAST PRODUCTION

PRE-CAST MAN HOLE & VALVE CHAMBER WITH COVER SLABS DATA SHEETS

01. HANDLING AND TRANSPORTATION

Precast segments are loaded to the transporting vehicle using by suitable machine .(Fig. 01)

Cannot be allow cantilevered edges during the transportation.

Always use all lifting hooks during handling.

Units are should be placed up side and down side during the handling and transportation.

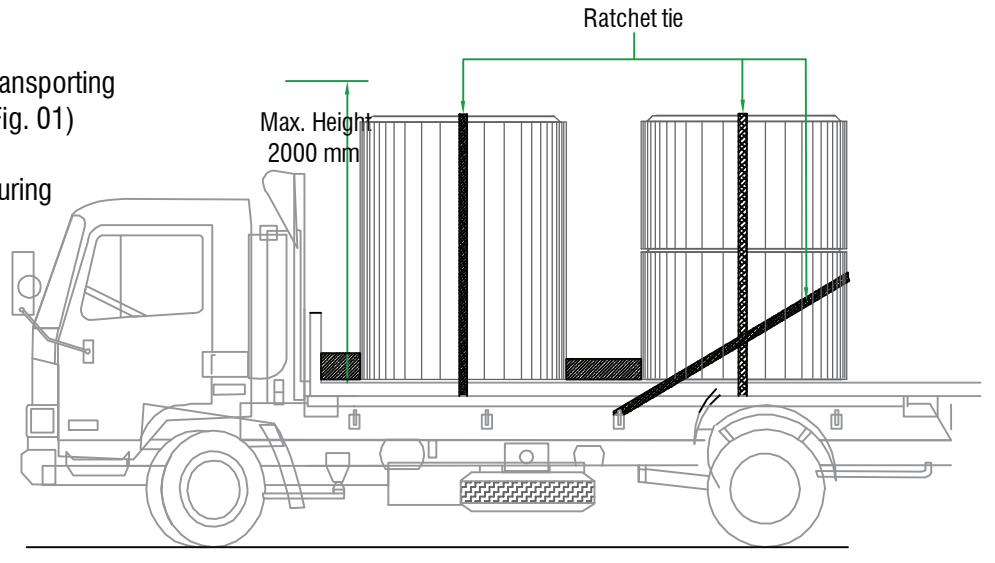

Fig.01 - Correct loading method for transportation.

Do not standing any workers & officers under the Product during the handling. always use the guiding rope for handling the product in to the required location.

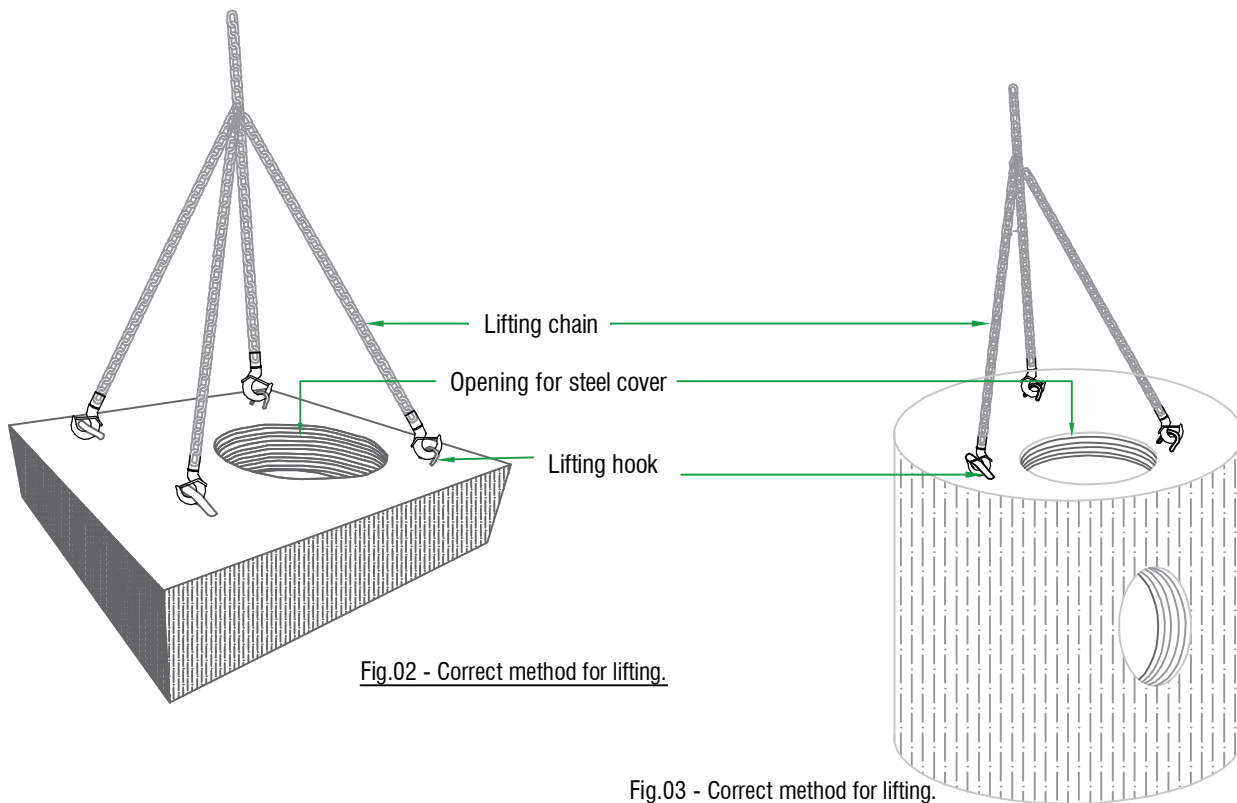

Fig.02 - Correct method for lifting.

Fig.03 - Correct method for lifting.

TESTING & INSPECTION

Material test report and mill report.

Concrete crushing strength (test cube strength)

International Construction Consortium (Pvt) Ltd

Precast Yard, # 508/2, Off Madapatha Road, Piliyandala, Sri Lanka.

Tel: +94 11 261 9160-4 Fax: +94 11 261 9164

Email: precast@icc-construct.com Web : www.icc-construct.com

