



PRE-CAST PRODUCTION

PRE-CAST CEMENT BLOCKS



DATA SHEET





PRE-CAST PRODUCTION

CEMENT BLOCKS - DATA SHEETS

01. INTRODUCTION

International Construction Consortium (Pvt)Ltd is a leading of manufacturer of Cellular cement blocks , solid cement blocks and associated cement block products in Sri Lanka. ICC brand cement blocks are accredited by Sri Lanka Standard Institution(SLS).

Cellular and solid blocks have become a superior alternative to burnt clay bricks. ICC cement blocks are used for internal and external wall construction.

The blocks are manufactured by using a modern PLC controlled block manufacturing plants with high quality controlling and quality assurance systems under engineering supervisions.

This publication provides the information necessary to specify cellular type and solid type blocks for all of these applications.



02. GENERAL SPECIFICATIONS

STANDARD SPECIFICATION

SLS Standard: 855 Part 1&2 :1989

PRODUCTION SPECIFICATION

Dimensions: Refer the table
 Min. Compressive Strength: 1.2 N/mm²
 Block Type : Cellular type / Solid type

RAW MATERIAL SPECIFICATION

Cement: SLS 107 : 2015
 Fine Aggregate: BS 882 - 1992
 Coarse Aggregate: BS 882 - 1992
 Water : BS 3148 - 1980

03. PRODUCT RANGE & DETAILS

CELLULAR AND SOLID TYPE		
LENGTH (MM)	WIDE (MM)	HEIGHT (MM)
390	100	190
390	150	190
390	200	190

04. DIMENSION DETAILS

The dimension as same cellular and solid type.

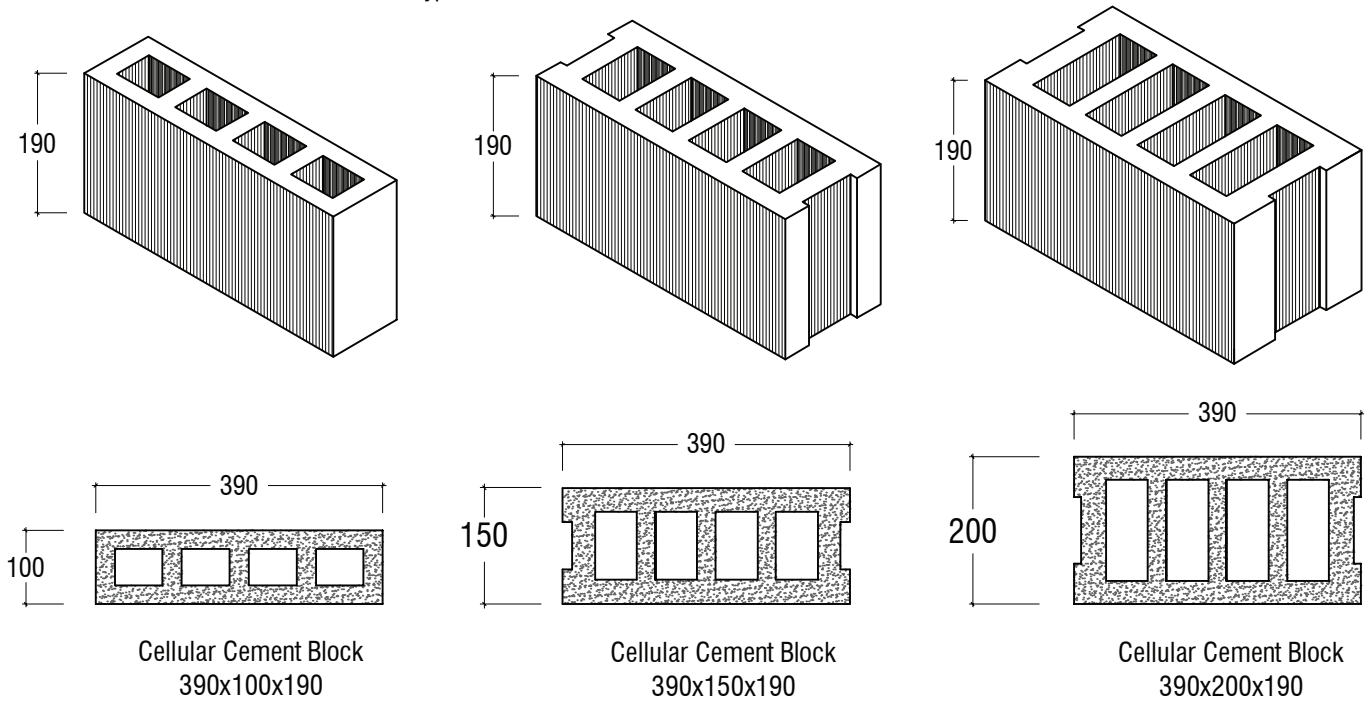

Table 03

Cellular Block Type	Quantity of 1 m ² (Nos)	Weight per each block ≈ (kg)
100	12.5	12
150	12.5	16
200	12.5	21

Table 04

Solid Block Type	Quantity of 1 m ² (Nos)	Weight per each block ≈ (kg)
100	12.5	16
150	12.5	22
200	12.5	31.5

05. HANDLING AND TRANSPORTATION

When the transportation of blocks they should be well packed to avoid the any damage due to clashes. They should be covered and tightened as shown in fig. 01.

Unload one block at a time safely(Anyway do not throw the block) and stack it in regular manner to minimize breakages. see Fig. 02

when the unloading by work men, they must wear hand gloves and follow the suitable safety methods.

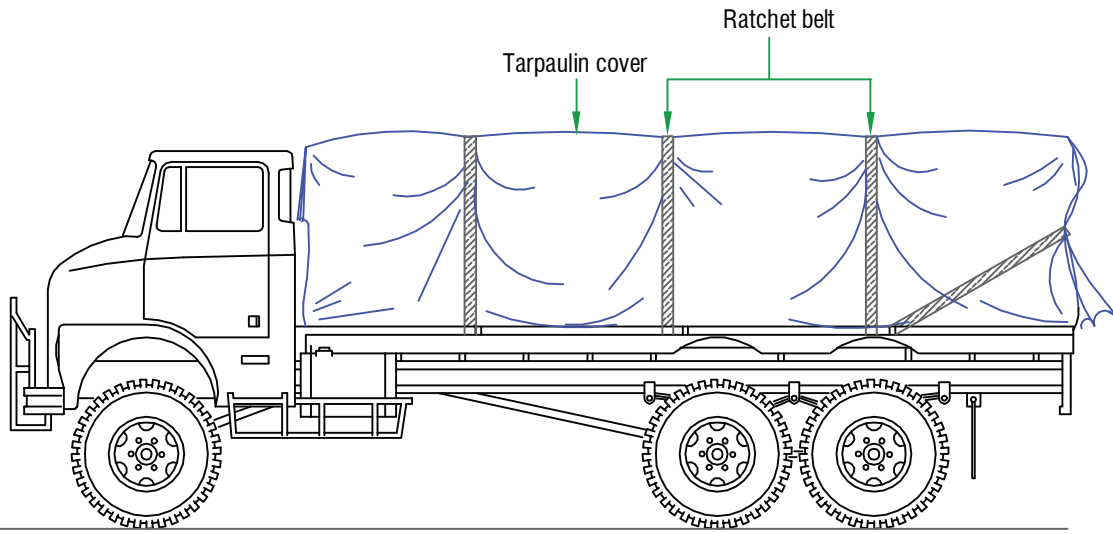

While transportation, make sure to fully cover and tighten with ratchet belt for safety purpose. (fig. 01)

Fig.01 - Correct loading method for transportation.

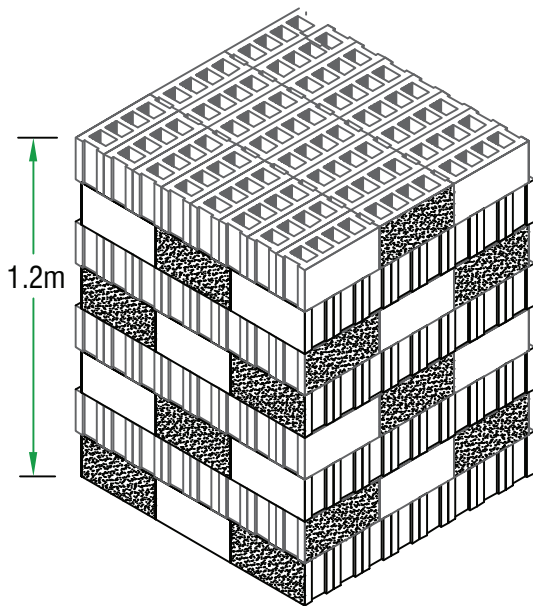

Fig.02 - Correct stacking method.

Do not stack exceeding the height of 1.2m

When the stacking of cement blocks, it is recommended not to exceed the height over 1.2m.



06. TESTING & INSPECTION

- *Material test report and mill report
- *Compressive strength. SLS 855 : part 2:1989